

SC 303/SC 313 Coin Counters



User's Guide

 **SCAN COIN**

013264-101_rev-05

© SCAN COIN AB 2011



User's Guide

SCAN COIN SC 303/313

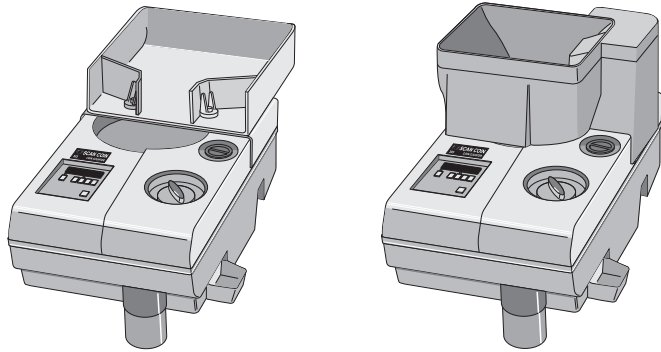

General Information	2
Declaration of Conformity	2
FCC Standar	2
Environmental Compliance	2
Responsibility	2
Safety Precautions	3
Introduction	4
Software Version	4
Accessories	4
Machine Part Terminology	4
Control Panel	5
Positional References	5
Modes of Operation	5
Continuous counting	5
Batch counting	5

Installation	6
Warning Labels	6
Machine Label	6
Operation	7
Getting Started	7
Continuous Counting	7
Batch Counting	7
Setting a Temporary Batch Stop	8
Changing a Fixed Batch Stop	8
Clearing a Blocked Coin Exit	8
By-passing Automatic Stop	9
Troubleshooting	9
Blank display/Machine Does not Start	9
Too Few Coins in the Bag in the First Batch	9
Maintenance	10
Cleaning	10
Cleaning the Coin Track	10
Changing Outfeed Belt	10
Technical Data	11

General Information

SCAN COIN AB reserves the right to revise and improve its products as it sees fit. This publication describes this product at the time of publication and may not reflect the product at all times in the future.

This publication, or parts thereof, may not be reproduced in any form, by any method, for any purpose other than the purchaser's personal use, without the express permission of SCAN COIN AB, Sweden.

Declaration of Conformity

We, SCAN COIN AB, Malmö, Sweden, declare under our sole responsibility, that the product in this manual, is in conformity with the following standards and/or other normative documents:

- EN 60 950-1:2006 + A11(2009) + A1(2010)
- EN 61000-6-1 (2007)
- EN 61000-6-3 (2007)

following the provisions of:

- Low Voltage Directive 2006/95/EC;
- EMC Directive 2004/108/EC.

FCC Standard

FCC Part 15 (2008): Radio frequency device, subpart B: Unintentional radiators. Class B equipment.

Environmental Compliance

WEEE Directive (valid in the EU only)



Waste Electrical and Electronic Equipment Directive
2002/96/EC.

Equipment marked with this symbol must be treated separately and in accordance with the local legislation that requires proper treatment of, recovery and recycling of used electric and electronic equipment.

Contact your SCAN COIN representative for further details.

Responsibility

The supplier of the equipment accepts no responsibility for injury or damage to personnel or equipment, if the equipment is altered in any way or used in a manner for which it was not intended at the time of delivery.

If the conditions for use of the equipment are changed, the supplier must be contacted or the declaration of conformity is invalidated.

Safety Precautions

This guide contains hazard information which **must** be read by all users. The hazard information is presented as follows:



WARNING!

Risk of personal injury!

Warnings indicate a potential hazard to the health and safety of users. They clearly state the nature of the hazard and how to avoid it. The warning symbols appear at their points of application in this guide.

Caution!

Cautions indicate a hazard to the machine, but **not** a danger to personnel. They clearly state how to avoid the hazard. They appear at their points of application in this guide.



WARNING!

Risk of electric shock!

Lethal voltages exist in the machine when connected to mains power. Make sure you disconnect the power cord before cleaning or servicing the machine.



WARNING!

Risk of electric shock!

The machine is of metal construction and must therefore always be earthed to the supply. Ensure that both the plug on the supply lead and the supply source are earthed. This is a requirement for this type of equipment and if not adhered to will contravene the national and international standards of Health and Safety in the work place.



WARNING!

Risk of jamming!

This machine contains moving parts and sharp edges. Always be careful. Do not touch the components inside the machine while it is running.



WARNING!

Risk of tipping!

During bagging, do not exceed the load stated on the label (see ["Warning Labels" on page 6](#)).

>>>

>>>



WARNING!

Risk of impaired hearing!

Use ear protectors while the machine is running.



WARNING!

Risk of jamming!

Switch off and disconnect the machine before opening the right hand cover. A function switch stops the motor if the cover is removed but the motor can start if the switch is activated making it possible to get fingers caught.



WARNING!

Risk of entanglement!

Keep long sleeves, ties, necklaces and long hair that can get caught by belts or pulleys away from the machine when the right hand cover is removed. If the function switch is activated by mistake the motor may start.

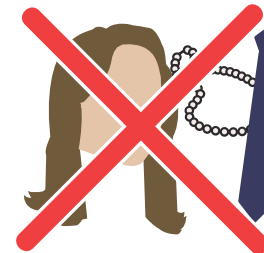

Introduction

The SC 303/313 is a compact desktop, universal coin counting machine. The machine is light and easy to operate.

The coins are loaded into a coin tray and after counting appear at a coin outlet. There is a separate outlet for rejected coins.

Smaller coins than the one selected will be rejected.

The control panel is located on top of the machine. A six digit digital display unit displays the number of coins counted as well as the batch quantities.

Two separately mounted knobs are used to set the coin diameter and coin thickness.

Software Version

This User's Guide relates to software version 4.03.

Accessories

For information about the accessories available, please contact to your SCAN COIN representative.

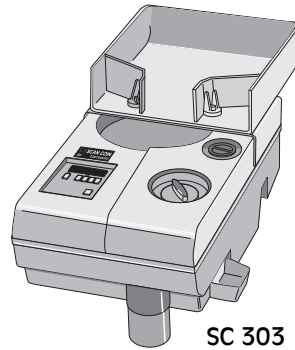

SC 303

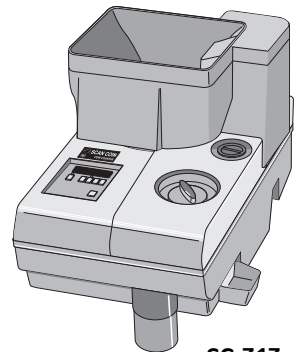

SC 313

Machine Part Terminology

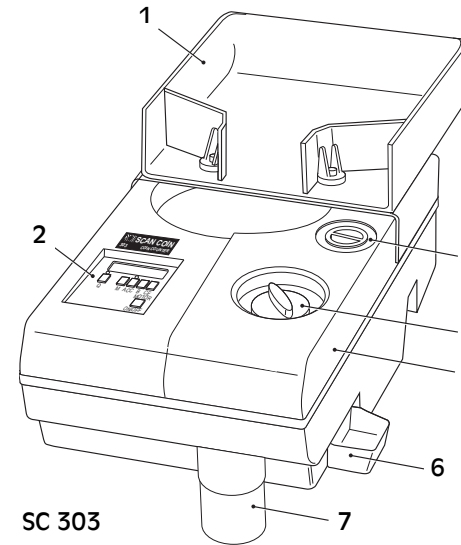

SC 303

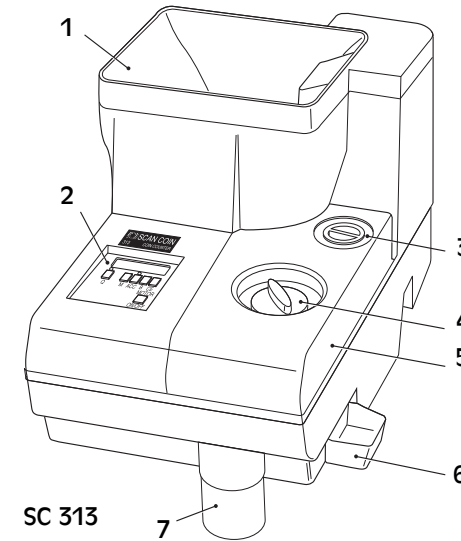

SC 313

- 1 Coin tray
- 2 Control panel
- 3 Thickness selector
- 4 Diameter selector
- 5 Right cover
- 6 Reject tray
- 7 Coin outlet

Control Panel

Note!

The key must be kept pressed for a few seconds before the function gets activated.

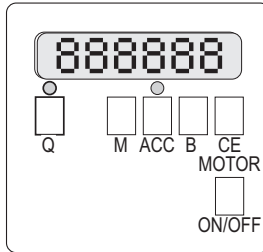

Key	Function
MOTOR ON/OFF	Starts and stops the machine.
Q	For selecting batch stop or continuous counting.
M	Resets the display and transfers counted coins to the memory.
ACC	Shows the number of counted coins stored in the memory.
B	Shows the contents of bag or tube (number of coins before reset).
CE	Clears the display.

Positional References

Unless stated otherwise, positions and directions such as left, right, upper, lower, rear, clockwise and counter-clockwise are given with respect to the machine when viewed from the front.

Modes of Operation

The SC 303/313 has two modes of operation, continuous counting and batch counting.

Continuous counting

The machine will count the coins and the display will continuously be updated with the number of coins counted.

Normally, if no coins pass the coin detector for five seconds the rotating disc stops and automatically reverses slightly before restarting. If no coins pass during the next 15 seconds the disc will stop automatically. This may occur because:

- there are either no more coins to count or
- the flow of coins has been blocked.

This function can be by-passed if desired (see [“By-passing Automatic Stop” on page 9](#)).

Batch counting

The machine will count the coins up to a fixed batch stop quantity and then stop. There are seven fixed batch stop quantities at 20, 25, 40, 50, 100, 500 and 1 000. In addition to these there is a temporary batch stop quantity, see [“Setting a Temporary Batch Stop” on page 8](#) which can be set anywhere between 5 and 10 999. This is used if the quantity of coins to be counted does not exist as a fixed batch stop quantity setting.

Installation



WARNING!

Risk of electric shock!

Follow the ["Safety Precautions" on page 3.](#)

Caution!

The machine must be protected by a fuse or a circuit breaker in the electrical circuit.

Please also note the following when installing the machine:

- Operating temperature 15–35 °C
- Operating humidity 30–80% R.H.

Do not place the machine close to any radiators. Make sure there is some free space around the machine that allows the air to circulate.

Make sure that the machine is positioned so that the socket outlet is easily accessible.

If the plug on the supply lead to the machine has a fuse, make sure it has the correct rating in amps.

Although this machine has been tested and complies with the national and international standards/regulations, it is recommended that no kind of equipment which generate a high level of electromagnetic interference (EMI) or vibration is placed close to the machine.

Warning Labels



Machine Label

The label below is an **example** of the information available on the machine.

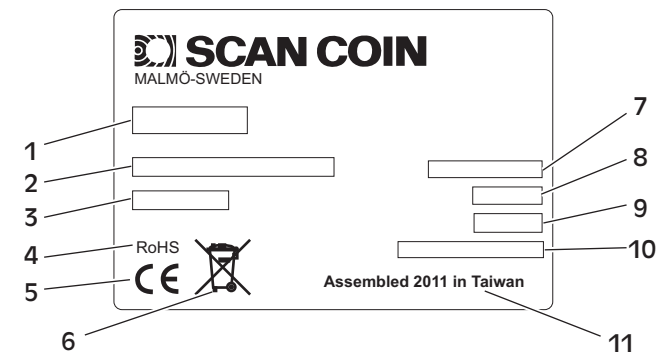

- | | |
|------------------|----------------------------------|
| 1 Machine type | 7 Supply voltage |
| 2 Machine No. | 8 Frequency |
| 3 Serial No. | 9 Current consumption |
| 4 RoHS compliant | 10 Fuse |
| 5 CE-symbol | 11 Year and place of manufacture |
| 6 WEEE-symbol* | |

*) See ["Environmental Compliance" on page 2.](#)

Operation



WARNING!

Risk of jamming!

Follow the ["Safety Precautions" on page 3.](#)

Getting Started

- At the rear of the machine, ensure that the mains supply lead is connected.
- Set the main switch to the ON position.

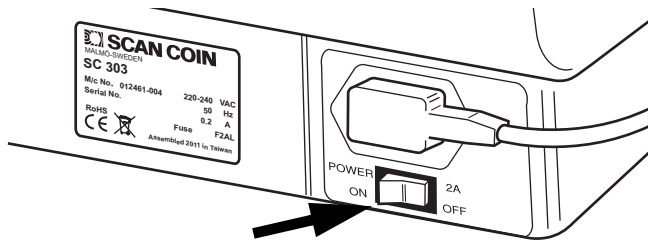

Continuous Counting



WARNING!

Risk of tipping!

Follow the ["Safety Precautions" on page 3.](#)

- Select the proper settings for coin diameter and thickness for the coins to be counted by using the two knobs on the top of the machine.
- Pour the coins to be counted into the coin tray.
- Press **Q** several times until the LED above is **not** lit and **0** is displayed. This indicates that the continuous counting mode has been selected.

>>>

>>>

- Press **MOTOR ON/OFF**.

The machine starts to count and the display continuously shows the number of counted coins.

- To stop the machine while counting, press **MOTOR ON/OFF**.
- To add the number of coins counted to memory, press **M**. The display will reset to zero and the LED above **ACC** will be lit, indicating that there is something stored in the memory.
- To view the contents of the memory, press and hold **ACC**.
- To clear the contents of the memory, press **CE** while holding down **ACC**.
- To reset the display, press **CE**.

- During the counting operation check for rejected coins and put any valid coins back into the coin tray.

Note!

The maximum number of coins that can be displayed is 999 999. When this value has been reached the machine will stop and the display will flash to indicate overflow.

Batch Counting

By pressing **Q** several times the machine will display the seven fixed batch stops sequentially.

- Select the required batch stop and hold down **Q**.

The selected batch stop number is displayed on the left and the batch quantity on the right. The LED above **Q** will also be lit indicating that the machine is in batch counting mode.

Note!

Press **B** to check that the partial batch register reads zero before starting. If not, press **B** and **CE** at the same time to reset.

- Press **MOTOR ON/OFF**.

The machine will start counting and will stop when the batch stop is reached. The LED above **Q** flashes when a full batch is reached.

>>>

>>>

- c) If there are more coins to count, press **MOTOR ON/OFF** to continue.
- d) During the counting operation, check for rejected coins and put any valid coins back into the coin tray.
- e) If the last batch count is incomplete, indicated by the LED above **Q** not flashing, press **B** to display the number of coins in the bag (partial batch register).
- f) To reset the partial bag register, press **B** and **CE** at the same time to reset the partial batch register.
- g) To exit the batch counting mode, repeatedly press **Q** until the LED above **Q** is **not** lit.

Setting a Temporary Batch Stop

- a) Press and hold **Q** while selecting the required batch number by means of the four control panel keys (**M**, **ACC**, **B** and **CE**).
The figure **9** will appear at the far left of the display, indicating that you are working with a **temporary** batch quantity.
- b) Release **Q**.
The machine is now ready to count the temporary batch.
- c) Proceed to count the batch as described in [“Batch Counting” on page 7](#), steps b to g.

Note!

This temporary batch is not stored in the memory of the machine and will be lost when the machine is turned off or when another batch stop is selected.

Changing a Fixed Batch Stop

- a) Press **Q** and switch on (**ON**) the machine.
- b) When the display changes from showing a row of the digit **8**, release **Q**.
The machine is now in the programming mode. The figure at the far left of the display is the fixed batch stop reference number (**1-7**) and the other figures the batch quantity (**5-10 999**).
- c) Press **Q** several times until the display shows the desired batch stop reference number.
- d) Press the keys below to change the fixed batch stop quantity setting.
Every time the **M**, **ACC**, **B** or **CE** key is pressed the displayed digit(s) immediately above the pressed key is changed.
- e) To change another fixed batch stop quantity, return to step c.
- f) When all the required fixed batch stop quantities have been changed, press and hold **MOTOR ON/OFF** until the digit on the far left disappears.
All of the fixed batch stop quantities are now in the memory and will remain there also when the machine is switched off (**OFF**).

Clearing a Blocked Coin Exit



WARNING!
Risk of jamming!
Follow the [“Safety Precautions” on page 3](#).

If a too large coin blocks the coin exit:

- a) Set the coin diameter and thickness knobs to their maximum settings.
- b) Open the right cover and manually turn the disc to get the coin rejected when it passes over the reject chute.
- c) Reset the coin diameter and thickness knobs to their desired settings and put any valid coins into the coin tray.
- d) Press **MOTOR ON/OFF** to resume counting.

By-passing Automatic Stop

Normally, if no coins pass the coin detector for five seconds the rotating disc stops and automatically reverses slightly before restarting. If no coins pass during the next 15 seconds the disc will stop automatically.

- Hold down **CE** while switching on the machine.
The display will read **StOP 0**, indicating that the automatic stop function has been switched off.
- Repeat this to re-engage the automatic stop function.
The display will now read **StOP 1**, indicating that the automatic stop function has been switched back on.

Troubleshooting



WARNING!

Risk of electric shock!

Follow the ["Safety Precautions" on page 3.](#)



WARNING!

Risk of jamming!

Follow the ["Safety Precautions" on page 3.](#)

Blank display/Machine Does not Start

- If the display is blank when the machine has been switched on, check the mains lead.
- If it is properly connected and the machine is still not working, contact your SCAN COIN representative.

Too Few Coins in the Bag in the First Batch

The last batch from the previous count was not full.

- Press **B** and **CE** to reset the batch-register and recount the batch, see ["Batch Counting" on page 7](#), step b.

Note!

If the right hand cover is removed from the machine, a function switch stops the motor.

Maintenance



WARNING!

Risk of electric shock!

Follow the ["Safety Precautions" on page 3.](#)



WARNING!

Risk of jamming!

Follow the ["Safety Precautions" on page 3.](#)

Cleaning

Clean the machine daily to prevent from accumulation of dirt, since this may cause too many coins to be rejected.

Caution!

Only use cleaning materials and implements which do not scratch.

Cleaning the Coin Track

Clean the coin track at regular intervals to ensure high counting performance.

- Remove the right hand cover.
- Raise the outfeed belt (1) to gain access to the coin track.
- Pull the lever (3) to remove the coin access block (2).
- Clean the coin track with a stiff brush.
- Replace the coin access block and the outfeed belt.
- Replace the right hand cover.

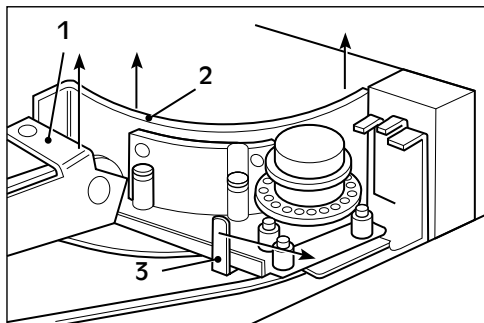

- 1 Outfeed belt
- 2 Coin access block
- 3 Lever

Changing Outfeed Belt

Change the outfeed belt when the machine has counted approximately one million coins.

- Set the coin diameter knob to minimum.
- Remove the right hand cover.
- Raise the outfeed belt (1).
- Lift the feed mechanism.
- Remove the old outfeed belt and exchange it for a new one.
- Replace the feed mechanism and the outfeed belt.
- Replace the right hand cover.

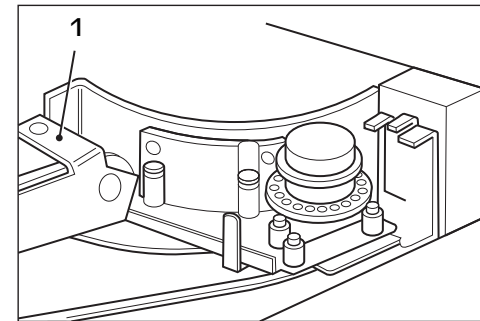

1 Outfeed belt

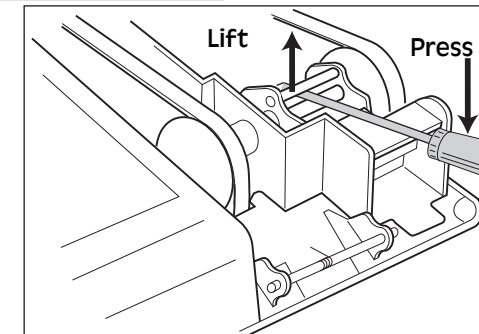

Technical Data

Part numbers:

SC 303.....012461-00x

SC 313..... 012462-00x

Supply voltage.....100–130/220–240 V AC

Frequency.....60/50 Hz

Current consumption..... 400 mA /200 mA

Counting:

Max. speed.....approx. 2 700 coins/minute

Coin diameter range.....14.0–34.0 mm (0.55–1.34")

Coin thickness range.....1.0–3.4 mm (0.04–0.13")

Display..... 6 digits

Batch range..... 5–10 999

Hopper volume:

SC 303..... approx. 2.0 litre

SC 313..... approx. 3.0 litre

Dimensions SC 303:

Width..... 220 mm (8.66")

Depth..... 370 mm (14.57")

Height..... 165 mm (6.50")

Dimensions SC 313:

Width..... 260 mm (10.24")

Depth..... 370 mm (14.57")

Height..... 315 mm (12.40")

Weight:

SC 303..... 8.4 kg (18.52 lbs)

SC 313..... 11.6 kg (25.57 lbs)

Noise level (during operation):

SC 303......86 dB (A)

SC 313......84 dB (A)